

12 V 314 Ah PLUS USER MANUAL



12V 314 Ah
GR8D PLUS

Deep cycle/Starting
Décharge profonde/ Démarrage

Volthium
Energy ∞

LITHIUM IRON PHOSPHATE

SUMMARY

1. Safety	3
1.1 Statement	3
1.2 Specification	3
1.3 Critical safety info	3
1.4 Battery maintaining	3
1.5 Waste disposal	4

2. Installation	4
2.1 Tools and equipment	4
2.2 Battery placement	4
2.3 Battery supporting materials	5

3. Introduction to Volthium PRO series batteries	5
3.1 Main features	5
3.2 Product appearance	5
3.3 Battery performances	10
3.3.1 Parameters	10
3.3.2 Firt use	10
3.3.3 Heating function	10
3.3.4 Remote On/Off	11
3.3.5 Active balancing	11

4. Series and parallel connection of batteries	11
4.1 Introduction	11
4.2 Parallel usage	11
4.3 Serial usage	12
4.4 Simultaneous series and parallel	12
4.5 Battery communication	13
4.5.1 Battery communication networking function	13
4.5.2 Networking operation	13

5. Charging requirements	13
5.1 AC-DC charger	14
5.2 Photovoltaic charging	14
5.3 Charging with an AC generator through a DC-DC charger	14
5.4 Recommended charging voltage	14

6. Battery recycling	14
-----------------------------------	----

7. Transportation and storage	14
--------------------------------------------	----

8. Warnings and attentions	14
-----------------------------------------	----



1. Safety

1.1 Statement

Please read this manual carefully before installation, operation, and maintenance, and pay attention to various warning signs and statements on the equipment. After reading this manual, please keep it properly for future reference.

1.2 Specification

These manual contents using the following symbols should be paid special attention to during operation.

Symbol	Statement
 ATTENTION	Attention: Reminder of precautions during operation.
 WARNING	Warning: Indicates that there is a hazardous situation during the operation process and special attention needs to be paid.

1.3 Critical safety info

Before installing, operating, or maintaining the battery, the following operating and maintenance instructions must be read.

Before installing :

- It is very important and necessary to carefully read the user manual before installing or using the battery. Failure to follow any instructions or warnings in this document may result in electric shock, serious injury, or damage to the battery and the entire system.
- Before connecting the battery pack to your device, check the voltage and ensure that they are within the limits of your device specifications. Failure to comply with these specifications will void your warranty.

During installation :

- Personnel familiar with the electrical specifications of their country or region are required to install battery packs. For optimal safety, please follow the steps described in this manual. The environmental conditions specified in the product specification must be followed.

ATTENTION

- Prohibit connecting batteries to different types of batteries;
- Do not use faulty or mismatched chargers to charge the battery;
- Long term float charging is prohibited for lithium-ion batteries;
- The environmental conditions given in the product documentation must be followed;
- If the battery is found to be deformed, abnormally hot, or emitting an odor, please immediately cut off the power and stop using it.

1.4 Battery maintaining

1. Professional personnel should take care of the charging operation, ensure good contact between the plug and socket during the charging process, ensure normal operation of the charging equipment, and ensure good contact at all connection points of the battery pack. If there is an abnormality, it needs to be repaired before charging;

2. If there is a large amount of dust, metal shavings, or other debris on the upper cover and pole of the battery pack, clean it with compressed air in a timely manner to avoid using water or objects soaked in water for cleaning;
3. Try to avoid splashing water or other conductive objects onto the battery cover and pole during charging and discharging, such as when exposed to heavy rain for use;
4. Estimate the charging and discharging time of the battery or battery pack based on its actual usage status. Pay attention to observing whether there are any abnormalities in the battery or battery pack at the end of charging and discharging, such as voltage difference issues;
5. Check whether the conductive strip, voltage collection terminal, and other nodes are loose, detached, rusted, or deformed, ensuring that the battery pack is used in series or parallel reliable fixation (once/3 months).

1.5 Waste treatment



ATTENTION

Please handle packaging and replace components in accordance with the laws and regulations of the country or region where the battery pack is located. Do not mix batteries with daily waste for disposal.

2. Installation

2.1 Tools and equipment



Insulating gloves



Safety shoes



Tools

2.2 Battery placement

Gently place the battery pack face up on the support surface, do not lay it on its side or upside down, and do not place any covers above the pack. The schematic diagram of battery pack placement is shown in figure.



2.3 Battery supporting materials

NO.	Material name	Chart	QTY (Pcs)	SPEC
1	Communicated cable		1	100mm long, M12 circular communication interface at both ends
2	Battery		1	12 V 314 Ah Plus
3	Screw		2	M8 * 16 stainless steel screws







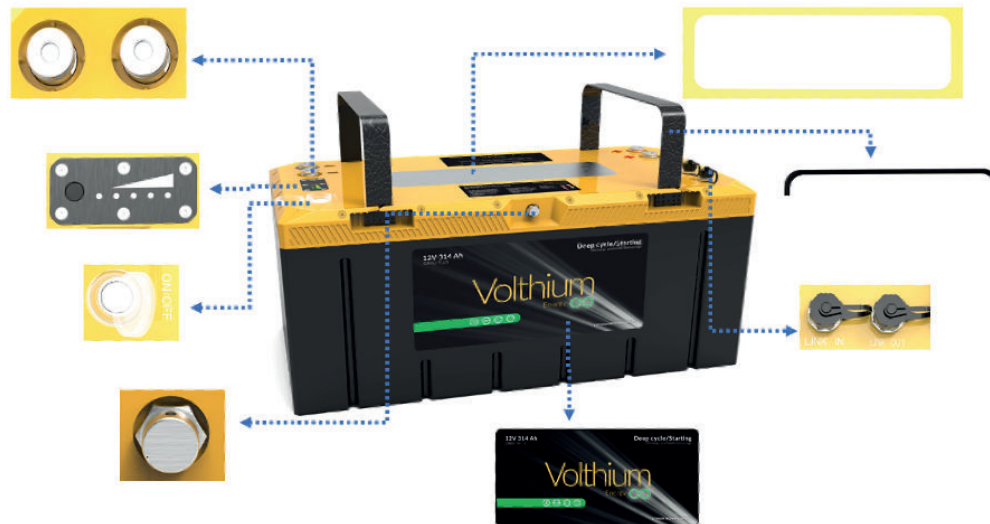

3. Introduction to Volthium series batteries

3.1 Main features

- a. LiFePO4 composition - providing excellent safety and lifespan
- b. High reliability
- c. Maintain consistent performance over a wide temperature range
- d. With higher heat dissipation effect, it can maintain high current charging and discharging of the battery for a longer time
- e. The communication function enables the battery to communicate with external devices through CAN, enabling better battery management

3.2 Product appearance



Components description			
NO.	Component appearance	Name	Statement
1		Terminal Posts	Negative and positive M8 terminal posts
2		Display panel	Check the SOC. running light to preliminarily determine whether the battery operates normally
3		Power switch	To power ON/OFF the battery
4		Pressure relief valve	IP67 to prevent lithium batteries from exploding in special circumstances
5		Label	Carefully read the label and use the battery correctly according to the label content
6		Fin	Disperse the heat inside the battery, be careful not to touch it with your hands
7		Handle	Convenient handling of batteries
8		Communication Port	Communication between batteries, or external inverter

1. Terminal Posts

Each battery has a positive terminal and a negative terminal. During use, be sure to identify and avoid reversing the positive and negative poles. After connecting the power line to the pole terminal, cover it with a protective cover to avoid short circuits.

2. Display panel

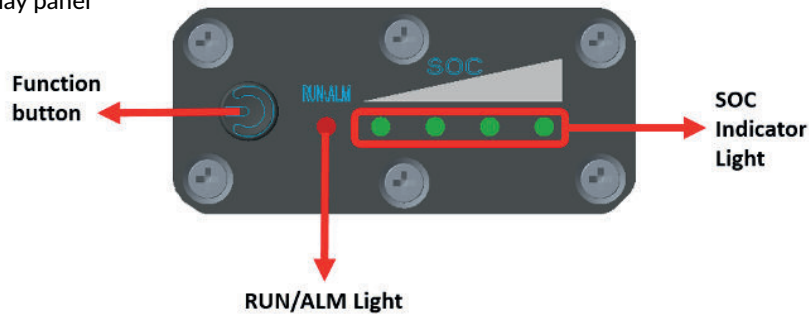

The battery display panel has 1 fault/running light, 4 SOC indicator lights, and 1 button: the usage as follow:
 RUN/ALM : One red/green light. It will display in green when the battery is normal; when there is a battery failure alarm or protection, it will display in red.

Explanation of indicator lights

Indicator light ●	Always on during charging or discharging	Flashing as Blink1 during standby
Indicator light ●	Always on when there is a malfunction	

Blinking mode	Lighting time	OFF time
Blink 1	0.25 S	3.75 S
Blink 2	0.5 S	0.5 S

SOC indicator lights: 4 green lights, representing different SOC according to different lighting methods.
 One light represents 25% SOC

Status	Charge				Discharge			
	L1 ●	L2 ●	L3 ●	L4 ●	L1 ●	L2 ●	L3 ●	L4 ●
0 - 25 %	Off	Off	Off	Blink2	Off	Off	Off	On
25 - 50 %	Off	Off	Blink2	On	Off	Off	On	On
50 - 75 %	Off	Blink2	On	On	Off	On	On	On
75 - 100 %	Blink2	On	On	On	On	On	On	On

Function button:

Press button for 1 s : show SOC for 10 s (before networking)

Press button for 3 s : release network

Press button for 10 s : start to network (marquee to assign address), then after networking, L1-4 display SOC always

Notes: For detailed information about the networking function, please refer to the "Networking Function" chapter.

3. Power Switch

The battery power ON/OFF switch is used to turn the battery on or off. When the battery is in the ON state, it indicates that the battery can be charged, discharged, and connected to Bluetooth;

When the battery is in the OFF state, it indicates that the battery is in a shutdown state, and cannot be charged or discharged, and cannot connect to the Bluetooth; When the battery is not used for a long time, please placing the switch in the OFF state in order to reduce the power consumption.

The lithium battery is equipped with an intelligent BMS (battery management system), which is designed to better protect the battery cell. From the OFF state to the ON state, the BMS performs a self-check, and the self-check time does not exceed 10 seconds. Therefore; the startup time is normal within 10 seconds.

4. Pressure relief valve

The waterproof grade is IP67, because the battery will generates heat during charging and discharging, which leads to thermal expansion. Adding a pressure relief valve can prevent the air pressure inside the battery box from rising, resulting in dangerous accidents. Make sure that there is no other object around the relief valve.

5. Label

The label displays the parameters. During use, it is important to match the corresponding charger and load according to the label parameters to avoid battery failure.

6. Fin

The fin is a battery cooling component, and rapid heat dissipation is beneficial for extending the battery life. At the same time, the fin is a hot decoration that cannot be touched by hand during battery use to avoid burns.

7. Handle

The handle is used for bearing the weight of the battery. When lifting the battery, pay attention to observing the stability of the handle to avoid the battery falling off.

8. Communication ports

There are two communication ports: LINK IN and LINK OUT. Pay attention during use. When the battery needs to communicate with inverter, a LINK IN needs to be connected;

A: Schematic diagram of single battery usage

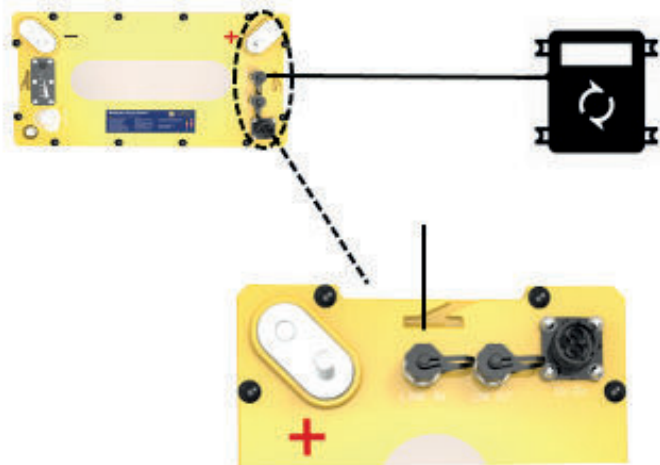

B: Please connect communication cables as follow step by step when multiple batteries are used in series and parallel

1. The inverter communication cable needs to be connected with the one of the batteries Link in.
2. The communication cables between batteries connect with each other as follow picture.

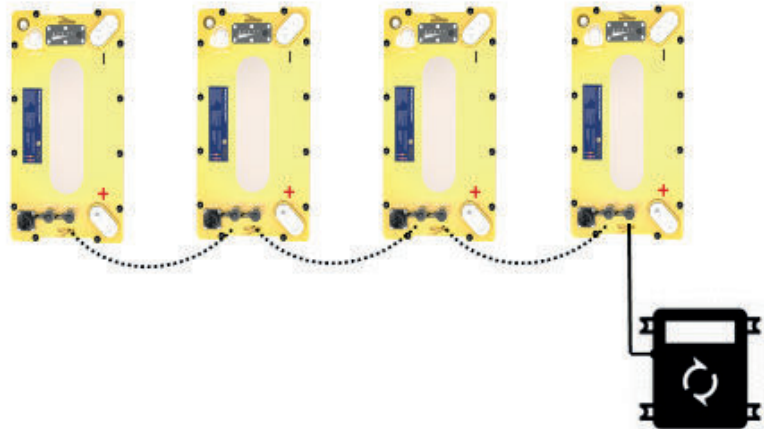

Top view	Pins no.	Link in	Link out	Usage
	1	CAN2H	/	Communication with external inverter
	2	CAN2L	/	
	3	CANH	CANH	Communication between batteries
	4	CANL	CANL	
	5	/	/	
	6	/	/	
	7	/	/	
	8	S1	/	OFF(Deep sleep): Connect S1 and S2 ON(Exit): Disconnect S1 and S2
	9	S2	/	
	10	/	/	

3.3 Battery performances

3.3.1 Parameters

Item	12 V 314 Ah Plus
Nominal voltage	12.8 V
Nominal energy	4019.2 Wh
Nominal capacity	314 Ah
Internal resistance@1khz AC	≤10 mΩ
Allowed MAX. charge current@25°C	150 A
Allowed MAX. discharge current@25°C	150 A
Recommend charge current	100 A
Recommend discharge current	100 A
Peal /Surge current limit	800 A@5 s, 200 A@10 min
Short circuit current	1500 A@500 μs

3.3.2 First use

1. Observe that there are no signs of the battery being removed.
2. When the battery leaves the factory, the button switch will be turned off and in the OFF state.
3. Before using the battery, it is necessary to close the switch to the ON state, and the LED display light will be on.

3.3.3 Heating Function

1. Charger heating

The battery features a low-temperature heating system. In cold weather conditions, the built-in heater will automatically activate when a charger is connected. The system first raises the battery temperature above 10°C before initiating the charging process.

2. Auto-heating

This battery is equipped with an automatic heating function. When no external charger is available, it can power the heating film through self-discharge from the battery cells. The heating film is tightly attached to the cells, thereby raising their temperature. This function can be configured via the Volthium Pro Series APP, allowing the user to set the start and stop temperatures to maintain the battery cell temperature within the specified range.

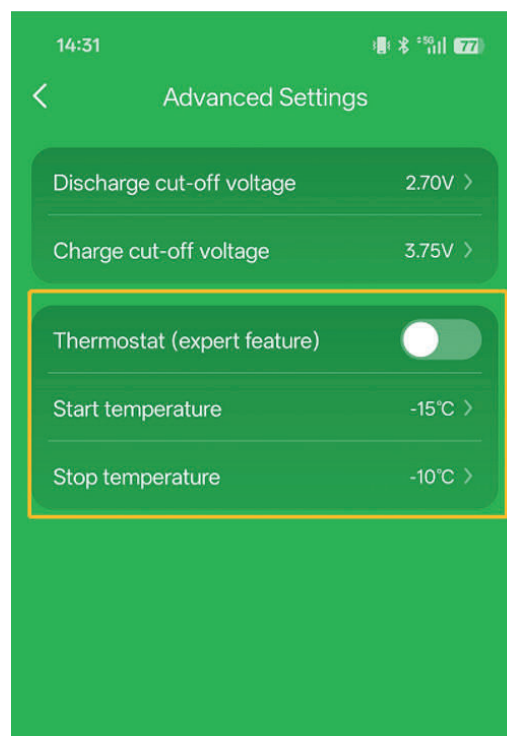

3.3.4 Remote On/Off

The battery can enter OFF (deep sleep mode) state via connecting S1 and S2 (pins on the LINK IN communication port, please refer to chapter 3.2 point 8) for all the time when the battery not be used for a long time, which can reduce the consumption. It takes around 15s to enter OFF state.

Disconnecting S1 and S2 will exit the OFF state, turn to ON state and then the battery can be use as normal.

3.3.5 Active balancing

The BMS features active cell balancing to optimize performance and lifespan by automatically redistributing energy between cells, ensuring voltage uniformity and preventing overstress. This improves capacity utilization, enhances safety, and extends battery life with minimal energy loss.

4. Series and parallel connection of batteries

4.1 Introduction

The 12V 314Ah battery allows multiple batteries to be connected in series or parallel up to 4S4P or 1S16P max., as well as simultaneously connected in series and parallel. This allows for the assembly of different voltage systems and the expansion of battery system capacity.

When multiple sets of batteries are connected in series and parallel at the same time, in addition to external power lines, communication lines be connected between the batteries, and internal communication between the batteries can better obtain battery information. One of the batteries can be set as the master battery, and the other batteries can be set as the slave battery. The master collects all information about other slave batteries, and communicate with external devices such as an inverter, display screens, etc.



ATTENTION

Before connecting batteries in series or parallel, it is necessary to pay attention to :

- The batteries must be the same model ! Different models, different capacities and different voltage platforms ar not allowed to be connected in series and parallel;
- Ensure that all parallel wires have the same length;
- We recommend 0.5 C for charging, that is, charging current=Nameplate capacity of battery * 0.5 C
- Before connecting the batteries in series, the voltage of each group of batteries must remain highly consistent. It is recommended that the voltage between batteries packs be: <200mV (@ 96%~100% SOC). After the batteries pack are connected in series, it will be charged and discharged as a whole system.

4.2 Parallel usage

When batteries are in parallel, a maximum of 16 batteries can be used. Before parallel connection, the voltage between each battery's positive and negative terminals must be verified using either a multimeter or the Bluetooth app, ensuring the voltage difference between any batteries does not exceed 200mV. If the voltage difference exceeds 200mV, each battery must be fully charged individually, left to rest for one hour, and then rechecked for voltage compliance before being connected in parallel. Always confirm all batteries meet the 200mV maximum voltage difference requirement prior to parallel connection to ensure safe operation.

For example, four 12.8 V 314 Ah batteries connected in parallel
 System voltage : 12.8 V System capacity : 314 Ah*4 = 1256 Ah

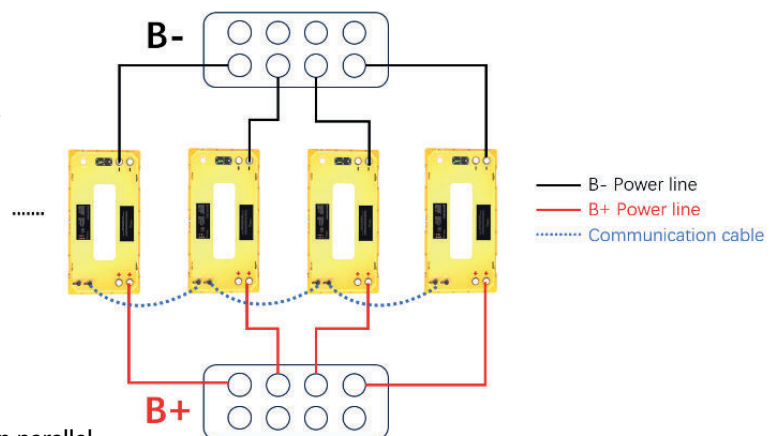

4.3 Serial usage

A maximum of 4 batteries can be used in series. Before connecting the batteries in series, a multimeter needs to be used to test the voltage between the positive and negative terminals of the battery. The battery voltage can be also checked through the Bluetooth APP to ensure that the voltage between the batteries does not exceed 150mV. If the voltage between the batteries exceeds 150mV, each battery needs to be fully charged separately, left for 1 hour, and then used in series. Series connection method: Connect the positive pole of the battery to the negative pole of the next battery, and so on.

For example, four 12.8 V 314 Ah batteries connected in series
 System voltage: $12.8\text{ V} * 4 = 51.2\text{ V}$ System capacity: 314 Ah

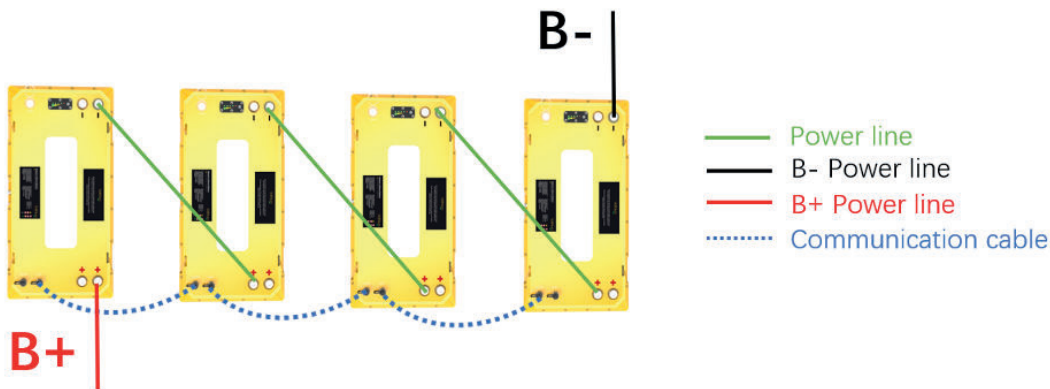

4.4 Simultaneous series and parallel

The batteries allow simultaneous use of batteries in series and parallel, with a maximum support of 4 series and 4 parallel applications. The connection method is: first in series, then in parallel, which means that the batteries are connected in series to form a high voltage, and then in parallel to form a high capacity.

When 1 battery is connected in series, 16 parallel connections are allowed max.
 When 2-4 batteries are connected in series, 4 parallel connections are allowed max.

For example: 16pcs 12.8V314Ah batteries, 4pcs in series & 4pcs in parallel
 System voltage: $12.8\text{ V} * 4 = 51.2\text{ V}$ System capacity: $314\text{ Ah} * 4 = 1256\text{ Ah}$

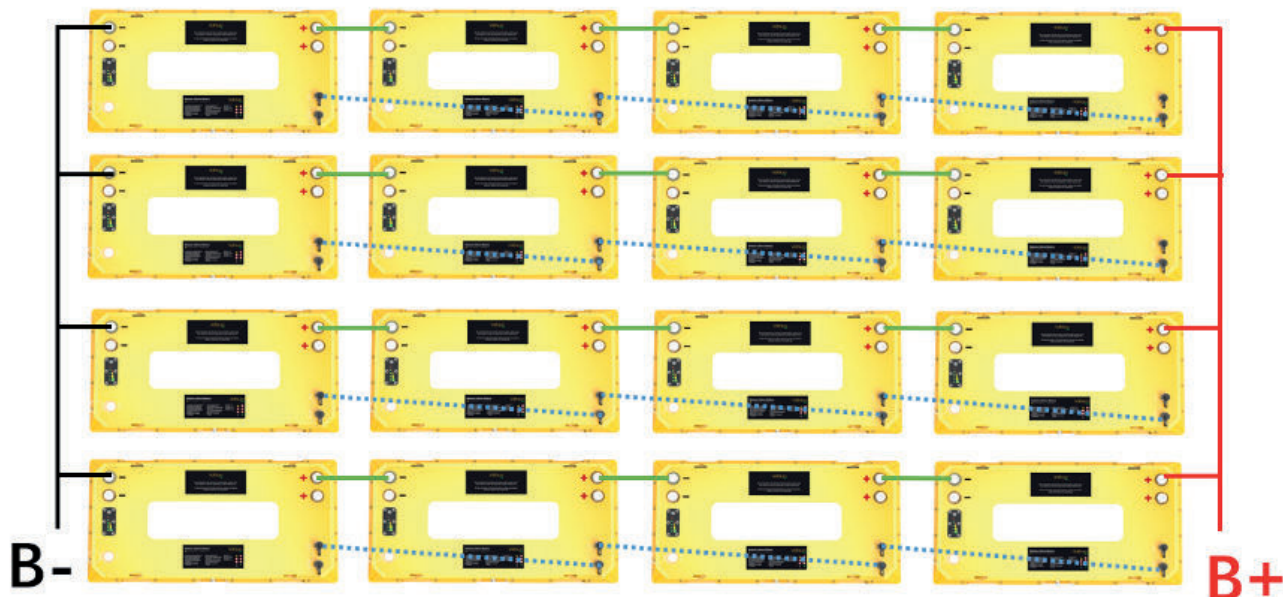

4.5 Battery communication

4.5.1 Battery Communication Networking Function

The batteries feature a communication networking function that enables data exchange between batteries and external devices (such as inverters or gauge). This function allows the system to summarize battery information for improved monitoring and control. The batteries can operate independently or as part of a networked system, making them ideal for smart energy applications.

Each battery is equipped with a Controller Area Network (CAN) bus interface, located at the top of the unit. Two M12-10pin circular connectors (labeled LINK IN and LINK OUT) allow for simple daisy-chain connections between batteries using the included CAN bus cable. When not in use, protective black covers should remain installed on the connectors to prevent environmental damage.

The CAN bus is not required for basic battery operation—the system will function normally without communication networking. However, when using multiple batteries, connecting them via the CAN bus enables efficient power management, optimized charging/discharging, and easier fault diagnosis. For proper cabling instructions, refer to Section 3.2, Point 8. For additional technical support, contact Volthium's engineering team.

4.5.2 Networking operation

After connecting the battery through the communication cable, it is necessary to use the Bluetooth connection method through the mobile phone's APP to network the battery.

Press the battery switch: switch from OFF to ON.

Assigning address: After pressing the master battery (the battery connected with external devices) function button on panel more than 10 seconds, the indicator light will start running. After all the indicator lights are off, it means that the internal address allocation of the battery is completed;



ATTENTION

The battery must be connected to the power line in a series first and then in parallel mode; The communication cables should first connect the first cluster of series connected batteries, and then connect the second cluster of series connected batteries, without confusion; The assigning address must be selected as the master battery. Press and hold the function button more than 10 seconds, and other slave batteries can be connected, which is particularly important as improper operation may result in battery networking failure.

APP operation (this step needs to match the use of the mobile app and enable the Bluetooth function of the phone): In the wired connection page of the APP, click "+" sign, set the system name, voltage platform (set as the voltage of a single battery), series number, parallel number according to the prompts, click next and connect the master battery to complete the networking. A maximum of 6 systems can be saved. After the connection is completed in the APP of one mobile phone, the APP of the other mobile phone can also enter the previously completed connection system.

5. Charging requirements

We recommend using a charging source with specific lithium charging settings to meet the following charging requirements to achieve the optimal performance and lifespan of Volthium series batteries.

Model	Max charge voltage	Cut-off voltage	Maximum charge current	Recommended charge current	Operation temperature
12 V 100 Ah	14.4 V	11.2 V	1 C	0.3 C	Charge : -20 - 60 °C (with heater) Discharge : -20 ~ 60 °C

Note: Batteries with heating function need to be heated before switching to charging mode.

5.1 AC-DC charger

Check if the AC-DC battery charger you plan to use has a dedicated lithium charging setting that meets the above charging requirements. Many battery chargers are only designed to charge Lead-acid battery and may not have appropriate lithium charging settings.

5.2 Photovoltaic charging

Check if the solar regulator you plan to use has a dedicated lithium charging setting that meets the above charging requirements. The Volthium series batteries can be charged using a solar regulator without lithium charging settings. However, it must be set to charge no more than 58.4V (4 batteries in series, with a maximum charging voltage of no more than 14.6V for a single battery). After the battery is fully charged, do not open the solar regulator without a suitable lithium charging setting.

5.3 Charging with an AC generator through a DC-DC charger

Check if the DC-DC charger you plan to use has a dedicated lithium charging setting that meets the above charging requirements. You can use a DC-DC charger without lithium charging settings to charge Volthium series batteries. However, it must be set to charge no more than 58.4V (4 batteries in series, with a maximum charging voltage of no more than 14.6V for a single battery), and then it must be turned off after the Volthium series battery is fully charged. After the battery is fully charged, do not turn on the DC-DC charger without a suitable lithium charging setting.

5.4 Recommended charging voltage

We strongly recommend a dedicated charger for lithium-ion batteries to better fully charge the battery. At the same time, according to the actual situation, AGM chargers can also be used to charge the battery, which can achieve varying degrees of effect.

6. Battery recycling

Volthium 12 V 314 Ah batteries are recyclable and should not be treated as household waste or landfill waste. If you need assistance in recycling batteries, please contact your dealer or Volthium's technical support engineer (as mentioned earlier in this manual).

7. Transportation and storage



ATTENTION

- During transportation, there should be no severe vibration, impact, or compression, and it should be protected from sunlight and rain.
- Handle with care during loading and unloading, and strictly prevent falling, rolling, and heavy pressure.
- The battery should be stored in a dry, clean, dark and well ventilated indoor environment for a long time. The recommended storage temperature range is 15~35 °C.
- The storage area is free of harmful gases, flammable and explosive materials, and corrosive chemicals.
- Batteries should be stored and transported at temperatures close to 50% SOC.
- If not used for a long time, the battery needs to be charged every 6 months according to the specifications.
- It is strictly prohibited to collapse, and the stacking should not exceed 6 layers, with the surface facing upwards.

8. Warnings and attentions

Please carefully read the battery specifications or instructions before use. Improper use may cause the battery to heat up, catch fire, rupture, damage, or decrease capacity. Energie Volthium Inc shall not be responsible for any accidents caused by not following our operating instructions.

**WARNING**

- The battery must be kept away from heat sources, high voltage, and directly exposed to sunlight.
- Do not throw the battery into water or fire.
- Do not invert the two terminals when using the battery.
- Do not connect the positive and negative poles of the battery to the conductors.
- Do not strike, throw, or step on the battery.
- Do not disassemble the battery without the manufacturer's permission and guidance.
- Do not mix batteries of different capacities and brands.

**ATTENTION**

- It is recommended to fully charge the battery every month to correct the battery SOC.
- When the battery is discharged, please charge the battery in a timely manner (≤ 2 days).
- Please use a dedicated lithium battery charger to charge the battery.
- Please stop using the battery when it emits odor, heat, deformation, or any abnormalities occur.
- Please place the battery away from children or pets.
- If the battery pack electrolyte leaks, please avoid contact with liquids or leaked gases. If the battery pack electrolyte leaks, please take the following steps immediately.
- Inhalation of gas: Evacuate personnel from the contaminated area and seek medical attention as soon as possible.
- Eye contact: Rinse eyes with water for 15 minutes and seek medical attention as soon as possible.
- Skin contact: Thoroughly rinse the exposed area with soap and water to ensure there are no chemicals or soap residues on it, and seek medical assistance as soon as possible.
- Swallowing: Try to induce vomiting and seek medical attention as soon as possible.
- Fire: Please use carbon dioxide fire extinguishers instead of liquid fire extinguishers to extinguish the fire.