

# TECHNICAL SHEET

## 12V 150AH BATTERY



Bluetooth (with Volthium Bluetooth Dongle \$)



Self-Heating (optional \$)



## ELECTRICAL SPECIFICATIONS

Voltage	12.8 volt
Capacity	150 Ah
Capacity @ 20A	450 min
Energy	1920 Wh
Auto-discharge	<3% per month
Maximum unit in series	4
Maximum unit in parallel	4

## CHARGE SPECIFICATIONS

Recommended Charge Current	5 A - 80 A
Maximum Charge Current	80 A
Recommended Charge Voltage	14.2 V - 14.6 V (Bulk) 13.6 V (Float)

## DISCHARGE SPECIFICATIONS

Continuous discharge current	150 A
BMS - Discharge disconnect voltage	10 V
BMS - Discharge reconnection voltage	11.2 V
Short circuit protection	Yes

## TEMPERATURE SPECIFICATIONS

Discharge temperature	From -30 to 60°C
Charging temperature	From 0 to 45°C

## STORAGE SPECIFICATIONS

Storage temperature	From -20 to 45°C
Storage voltage	From 13.1V to 13.3V

## COMMUNICATIONS SPECIFICATIONS

Bluetooth	Dongle BT require (accessory)
Communication ports	RJ45 (RS485)
LCD screen	No
Volthium CAN Hub Communication (VE.CAN)	Compatible

## HEATING SPECIFICATIONS (OPTIONAL)

Activation temperature	From -35 to 11 °C
Activation current	6 A
Heating current	4 A
System activation mode	----

## NUMBER OF CYCLES ACCORDING TO THE AVERAGE DISCHARGE % OF USE

30% discharge	8200 < cycles
80% discharge	6000 < cycles
100% discharge	3500 < cycles

## MECHANICAL SPECIFICATIONS

Dimensions	344,16 X 187,36 X 237,5 mm 13.55 X 7.4 X 9.35 po
Group / format	GR31
Weight	17.2kg / 38 lbs
Terminal Type	M8
Tightening torque on terminals	8~10nm / 6-8 ft/lb

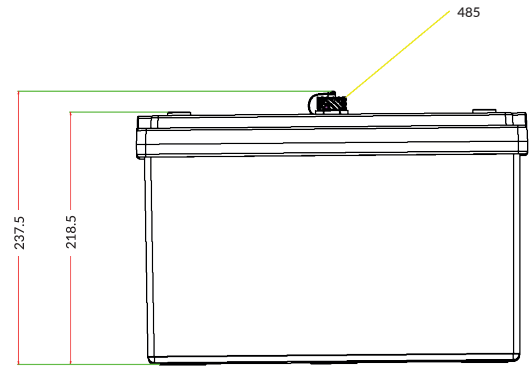

## CERTIFICATIONS & DESIGN

Design	4S1P
Certifications	Cells : UL1973
Shipping Classification	UN 3480   CLASS 9
Cell type	SquareCell - LiFePO4 - 150AH - 3.2V Grade A+

