

USER MANUAL

12V 100AH PRO BATTERY



SUMMARY

Safety	P.03	Data collection on windows computer	P.13
STATEMENT	P.03		
SPECIFICATION	P.03		
CRITICAL SAFETY INFO.	P.03		
BATTERY MAINTAINING	P.04		
WASTE DISPOSAL	P.04		
Installation	P.04	Charging requirements	P.13
TOOLS AND EQUIPMENT	P.04	AC-DC CHARGER	P.13
BATTERY PLACEMENT	P.04	PHOTOVOLTAIC CHARGING	P.13
BATTERY SUPPORTING MATERIALS	P.05	CHARGING WITH AN AC GENERATOR THROUGH A DC-DC CHARGER	P.13
		RECOMMENDED CHARGING VOLTAGE	P.14
		PASSIVE EQUALIZATION FUNCTION	P.14
Introduction to Volthium PRO series batteries	P.05	Battery recycling Transportation and Storage	P.14
MAIN FEATURES	P.05		
PRODUCT APPEARANCE	P.06		
FUNCTIONAL CHARACTERISTICS	P.08		
HEATING FUNCTION	P.09		
Series and parallel connection of batteries	P.09	Warnings and Attention	P.15
INTRODUCTION	P.09		
PARALLEL USAGE	P.10		
SERIAL USAGE	P.10		
SIMULTANEOUS SERIES AND PARALLEL	P.10		
BATTERY COMMUNICATION	P.11		
Convert M12 communication interface	P.12-13	10-year limited warranty Warranty statement Non-transferable warranty Warranty exclusions	P.16 P.16 P.16 P.16-17
		Non-warranty repairs Submitting a warranty claim Return and refund policy	P.17 P.17 P.17
		Annex TECHNICAL SHEET	P.18 P.19-20



Safety

STATEMENT

Please read this manual carefully before installation, operation, and maintenance, and pay attention to various warning signs and statements on the equipment. After reading this manual, please keep it properly for future reference.

SPECIFICATION

This manual contents using the following symbols should be paid special attention to during operation.

Symbol	Statement
 ATTENTION	Attention: Reminder of precautions during operation.
 WARNING	Warning: Indicates that there is a hazardous situation during the operation process and special attention needs to be paid.

CRITICAL SAFETY INFO.

Before installing, operating, or maintaining the battery, the following operating and maintenance instructions must be read.

Before installing

- It is very important and necessary to carefully read the user manual before installing or using the battery. Failure to follow any instructions or warnings in this document may result in electric shock, serious injury, or damage to the battery and the entire system.
- Before connecting the battery pack to your device, check the voltage and ensure that they are within the limits of your device specifications. Failure to comply with these specifications will void your warranty.

During installation

- Personnel familiar with the electrical specifications of their country or region are required to install battery packs. For optimal safety, please follow the steps described in this manual. The environmental conditions specified in the product specification must be followed.

ATTENTION

- Prohibit connecting batteries to different types of batteries
- Do not use faulty or mismatched chargers to charge the battery
- Long term float charging is prohibited for lithium-ion batteries
- The environmental conditions given in the product documentation must be followed
- If the battery is found to be deformed, abnormally hot, or emitting an odor, please immediately cut off the power and stop using it

BATTERY MAINTAINING

- ① Professional personnel should take care of the charging operation, ensure good contact between the plug and socket during the charging process, ensure normal operation of the charging equipment, and ensure good contact at all connection points of the battery pack. If there is an abnormality, it needs to be repaired before charging;
- ② If there is a large amount of dust, metal shavings, or other debris on the upper cover and pole of the battery pack, clean it with compressed air in a timely manner to avoid using water or objects soaked in water for cleaning;
- ③ Try to avoid splashing water or other conductive objects onto the battery cover and pole during charging and discharging, such as when exposed to heavy rain for use;
- ④ Estimate the charging and discharging time of the battery or battery pack based on its actual usage status. Pay attention to observing whether there are any abnormalities in the battery or battery pack at the end of charging and discharging, such as voltage difference issues;
- ⑤ Check whether the conductive strip, voltage collection terminal, and other nodes are loose, detached, rusted, or deformed, ensuring that the battery pack is used in series or parallel reliable fixation (once/3 months).

WASTE DISPOSAL



ATTENTION



Please handle packaging and replace components in accordance with the laws and regulations of the country or region where the battery pack is located. Do not mix batteries with daily waste for disposal.

Installation

TOOLS AND EQUIPMENT



Insulating gloves



Safety shoes





Tools

BATTERY PLACEMENT

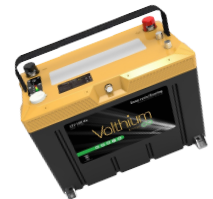
Carefully place the battery face up on the support surface, do not lay it on its side or upside down. Do not place any heavy objects on top of the battery. See below.

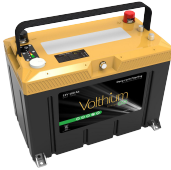

BATTERY SUPPORTING MATERIELS

NO	Material name	Chart	QTY (pes)	SPEC
1	Communicated line		1	500mm long, M12 circular communication interface at both ends
2	Battery		1	12.8V 100Ah
3	Screw		2	M8 * 12 stainless steel screw







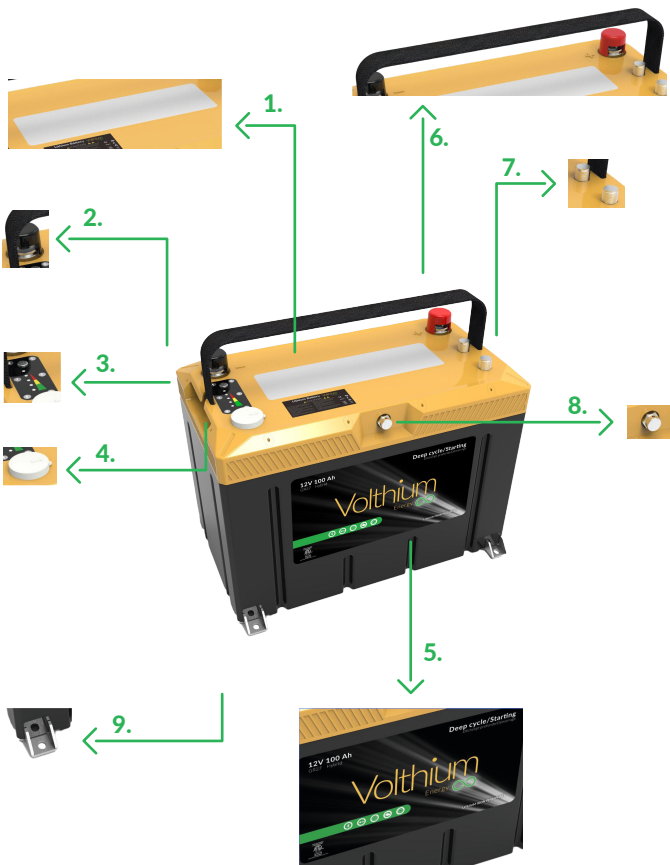

Introduction to Volthium PRO series batteries

MAIN FEATURES

- a. LiFePO4 composition - providing excellent safety and lifespan
- b. High reliability
- c. Maintain consistent performance over a wide temperature range
- d. With higher heat dissipation effect, it can maintain high current charging and discharging of the battery for a longer time
- e. The communication function enables the battery to communicate with external devices through CAN, enabling better battery management.

PRODUCT APPEARANCE



No.	Component Appearance	Name	Statement
1		Fin	Disperse the heat inside the battery, be careful not to touch it with your hands
2		Pole	M8 Terminal
3		Panel	Check the SOC, running light to preliminarily determine whether the battery operates normally
4		Switch	When the battery is not used for a long time, it can be disconnected to reduce self-consumption
5		Label	Carefully read the label and use the battery correctly according to the label content
6		Handle	Convenient handling of batteries
7		Port	Battery to battery communication, battery to external communication
8		Pressure relief valve	IP67 to prevent lithium batteries from exploding in special circumstances
9		Bracket	Convenient for fixing the battery on the ground

1. Heat sink

The heat sink is a battery cooling component, and rapid heat dissipation is beneficial for extending the battery life. At the same time, the heat sink is a hot decoration that cannot be touched by hand during battery use to avoid burns.

2. Pole terminal

Each battery has a positive terminal and a negative terminal. During use, be sure to identify and avoid reversing the positive and negative poles. After connecting the power line to the pole terminal, cover it with a protective cover to avoid short circuits.

3. Display panel

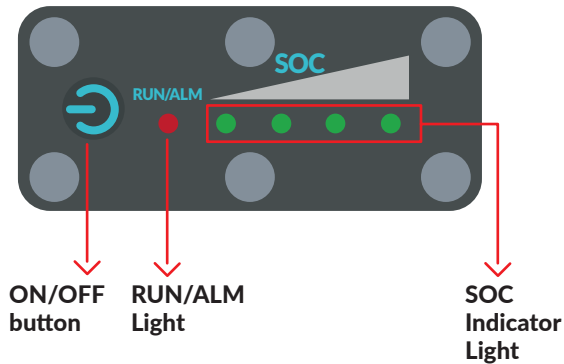

The battery display panel has 1 fault/running light, 4 SOC indicator lights, and 1 button: the usage method is as follows

RUN/ALM: One red light, one yellow light, displayed in green when the battery is normal; when there is a battery failure alarm or protection, it will display in red.

Explanation of indicator lights

Indicator light ●	Always on during charging or discharging	Flashing during standby 1
Indicator light ●	Always on when there is a malfunction	
Blinking mode	Lighting time	Off time
Blink 1	0.25S	3.75S
Blink 2	0.5S	0.5S

SOC indicator lights: 4 green lights, representing different SOC according to different lighting methods. One lamp represents 25% SOC

Status	Charge				Discharge			
	L1 ●	L2 ●	L3 ●	L4 ●	L1 ●	L2 ●	L3 ●	L4 ●
0-25 %	Off	Off	Off	Blink2	Off	Off	Off	On
25-50 %	Off	Off	Blink2	On	Off	Off	On	On
50-75 %	Off	Blink2	On	On	Off	On	On	On
75-100 %	Blink2	On	On	On	On	On	On	On

4. Battery switch

The battery switch is used to turn the battery on or off. When the battery is turned on, it indicates that the BMS of the battery is in a normal state and it can be charged, discharged and connected via Bluetooth; when the battery is off, it indicates that the battery is in a shutdown state and cannot be charged or discharged, and cannot be connected via Bluetooth; the battery enters a sleep state. When the battery is not used for a long time, turning the switch to the OFF position can reduce the power consumption of the BMS. The lithium battery is equipped with an intelligent BMS, designed to better protect the battery cell. From OFF state to ON state, the BMS performs a self-check which lasts no more than 10 seconds. Therefore, the boot time is normal within 10 seconds : Battery status display and communication activation.

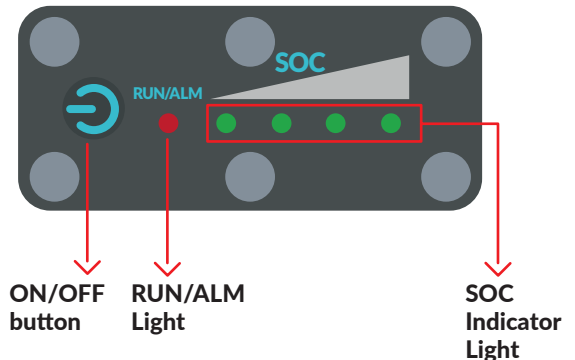

Usage method:

When using the battery for the first time, place the battery switch in the ON position; Short press the ON/OFF button for 1 second to prompt for battery SOC, and the LED will prompt for 10 seconds; Long press and hold the activation button for 10 seconds to activate the battery. After activation, the LED indicator light will indicate the SOC of the battery; Running light flashing yellow.

When battery networking, automatically match the address of the battery for use. For detailed purposes, please refer to the networking function.

5. Label

Labels are performance parameters displayed. During use, it is important to match the corresponding charger and load according to the label parameters to avoid battery failure.

6. Handle

The handle is used to bear the weight of the battery. When lifting the battery, pay attention to observing the stability of the handle to avoid the battery falling off.

7. Communication port

There are two communication ports: one is Link in and the other is Link out. Pay attention during use.

When the battery needs to communicate with external devices, a Link in needs to be connected;

A: Schematic diagram of single battery usage

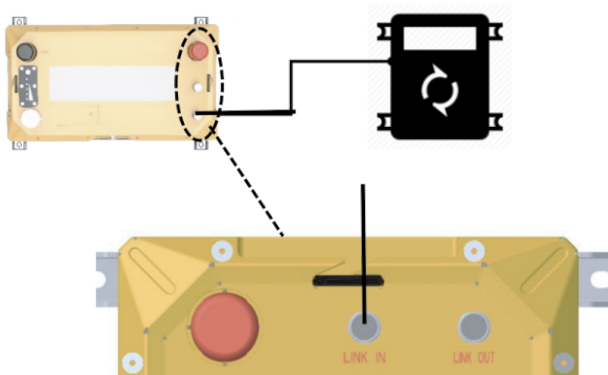

B: When multiple batteries are used in series or parallel, the external device communication line needs to be connected to the battery Link in;

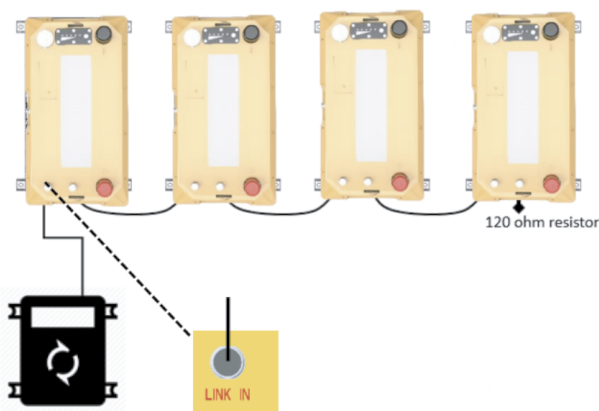

8. Pressure relief valve

The waterproof grade is IP67, because the battery is heating during charging and discharging, which leads to Thermal expansion. Adding a pressure relief valve can prevent the air pressure inside the battery box from rising, resulting in dangerous accidents.

Note : There is no other object around the pressure relief valve.

9. Installation bracket

Install the bracket to facilitate the installation of battery firmware into the vehicle body. It is recommended to use M6 stainless steel screws to secure the battery.

FUNCTIONAL CHARACTERISTICS

Item	12100	12200	12300
Nominal voltage	12.8V		
Nominal energy	1280Wh	2560Wh	3840Wh
Nominal capacity	100Ah	200Ah	300Ah
Internal resistance @ 1 khz AC	≤30mΩ		
Allowed MAX. charge current @ 25°C	100A	200A	300A
Allowed MIN. discharge current @ 25°C	150A	200A	300A
Recommend charge current	50A	100A	150A
Recommend discharge current	100A	150A	200A
Peal/Surge current limit	500A-3s	600A-3s	800A-3s
Short circuit current	1000A-500μs	1200A-500μs	1200A-500μs

First use

- ① Observe that there are no signs of the battery being removed.
- ② When the battery leaves the factory, the button switch will be turned off and in the OFF state.
- ③ Before using the battery, it is necessary to close the switch to the ON state, and the LED display light will be on.

Communication port

- ① 2 * Communication port with CAN communication;
- ② You can upgrade the battery program through the communication port;
- ③ It can communicate with other devices through the communication port.

Switch button

When the battery is in transportation or long-term storage, it can be turned off, which is extremely low self-consumption, ensuring that the battery can be stored for a long time without being discharged. At the same time, it is beneficial to improve the safety of the battery.

HEATING FUNCTION

The battery has a low-temperature heating function. When in cold weather, the battery is equipped with a built-in heater. When a charger is inserted, the built-in heater will automatically heat to above 0 ° C and then switch to charging mode.

Series and parallel connection of batteries

INTRODUCTION

The Pro Series battery allows multiple batteries to be connected in series or parallel, as well as simultaneously connected in series and parallel. This allows for the assembly of different voltage systems and the expansion of battery system capacity. For example, four 12.8V 100Ah batteries can be connected in series and parallel to form a 25.6V 200Ah battery system.

When multiple sets of batteries are connected in series and parallel at the same time, in addition to external power lines, communication lines can be connected between the batteries, and internal communication between the batteries can better obtain battery information. One battery can be set as the host battery, and the other batteries can be set as the slave battery. The host collects all information about other slave batteries, and can communicate with external devices such as inverters, display screens, MPPTs, etc.



ATTENTION

Before connecting batteries in series or parallel, it is necessary to pay attention to:

- a). The batteries must be of the same model, different models, different capacities, and different voltage platforms. Series and parallel connection is not allowed;
- b). Ensure that all parallel wires have the same length;
- c). We recommend 0.5C for charging, that is, charging current=Nameplate capacity of battery * 0.5C
- d). Before connecting the batteries in series, the voltage of each group of batteries must remain highly consistent. It is recommended that the voltage difference between battery packs be:
Voltage difference < 500mV (@ 0%~95% SOC); voltage difference < 400mV (@ 96%~100% SOC). After the battery pack is connected in series, it will be charged and discharged as a whole.

PARALLEL USAGE

A maximum of 16 batteries can be used in parallel. Before connecting batteries in parallel, a multimeter needs to be used to test the voltage between the positive and negative terminals of the battery. You can also check the battery voltage through the Bluetooth app to ensure that the voltage between the batteries does not exceed 0.5V, which can be connected in parallel. If the voltage between the batteries exceeds 0.5V, each battery needs to be fully charged separately, left for 1 hour, and then used in parallel.

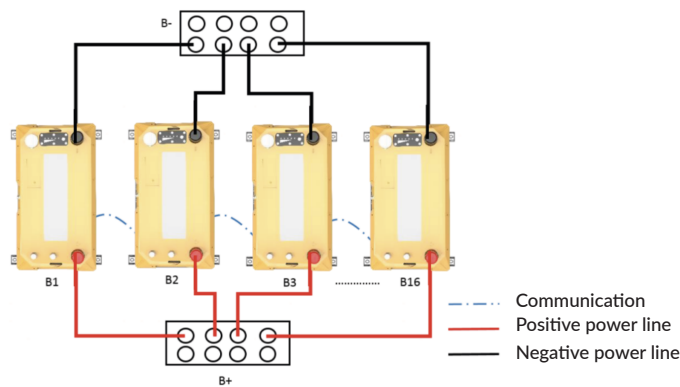

For example, two 12.8V 100Ah are used in parallel.
System voltage: 12.8V System capacity: 100Ah + 100Ah = 200Ah

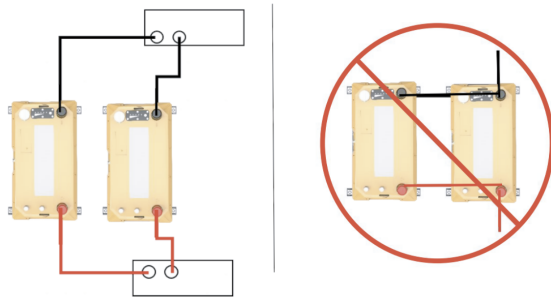

WARNING

Do not output positive and negative poles on the same battery, which may damage the battery.

SERIAL USAGE

A maximum of 4 batteries can be used in series. Before connecting the batteries in series, a multimeter needs to be used to test the voltage between the positive and negative terminals of the battery. You can also check the battery voltage through the Bluetooth app to ensure that the voltage between the batteries does not exceed 0.5V. If the voltage between the batteries exceeds 0.5V, each battery needs to be fully charged separately, left for 1 hour, and then used in series. Series connection method: Connect the positive pole of the battery to the negative pole of the next battery, and so on.

For example, two 12.8V 100Ah batteries connected in series
System voltage: 12.8V + 12.8V = 25.6V System capacity: 100Ah

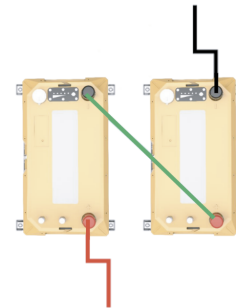

SIMULTANEOUS SERIES AND PARALLEL

Pro Series batteries allow simultaneous use of batteries in series and parallel, with a maximum support of 4 series and 4 parallel applications. The connection method is: first in series, then in parallel, which means that the batteries are connected in series to form a high voltage, and then in parallel to form a high capacity.

When 1 is connected in series, 16 parallel connections are allowed
When 2 are connected in series, 4 parallel connections are allowed
When 3 are connected in series, 4 parallel connections are allowed
When 4 are connected in series, 4 parallel connections are allowed

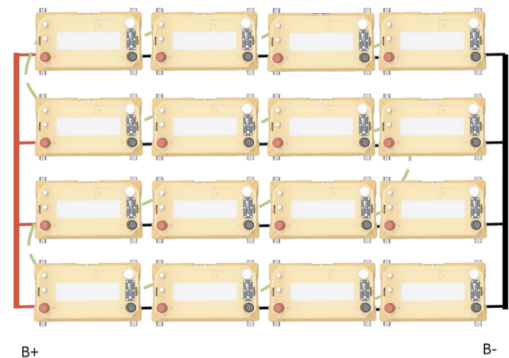

For example: 16pcs 12.8V100Ah batteries, 4pcs in series & 4pcs in parallel
System voltage: 12.8V * 4 = 51.2V
System capacity: 100Ah * 4 = 400Ah

BATTERY COMMUNICATION

Communication terminal connection way

The series of plus batteries have the function of communication networking between batteries. When communication with external devices is needed, the networking function can be used to enable the battery to summarize information. The battery can be used alone or used for communication networking, which is more prominent in some intelligent devices. When using this function, it is important to understand its purpose and carefully read the following instructions for correct operation.

The battery includes a Controller Area Network (CAN) bus communication interface. Two circular M8 DIN connectors are located at the top of the battery to connect one battery (Link out) to another battery (Link out) using a CAN bus cable in a simple daisy link wire method.

For normal battery operation, the CAN bus function is not required. Automatic operation and protection of batteries; It does not require any CAN bus communication or external devices (such as external controllers) or other CAN bus connected batteries to operate. Retain the two black covers installed on the two M12 connectors to protect them from environmental influences when not in use.

Communication line connection method:

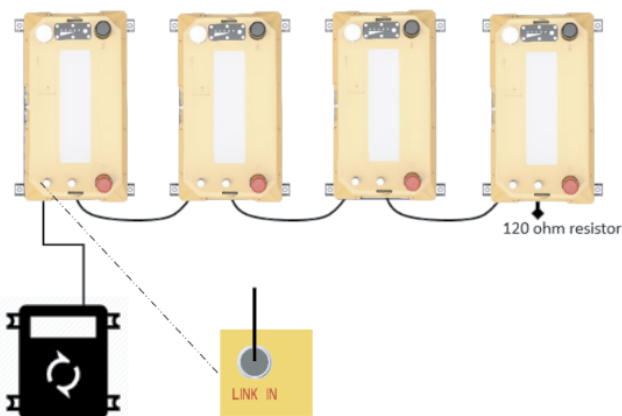

Each set of batteries is equipped with a dedicated communication line that connects the batteries using a CAN bus. This allows for communication between the battery and the load or charger, making it more efficient to use the battery. This is also beneficial for understanding battery faults. If you have more questions about the CAN bus, please contact Volthium's engineers for technical support.

Networking method

After connecting the battery through the communication cable, it is necessary to use the Bluetooth connection method through the mobile phone's APP to network the battery.

Equipment operation:

Wiring: When all batteries are turned off, use the power line to connect the batteries in series and parallel (first in series and then in parallel); Please refer to this chapter <4.2 Parallel Use>, <4.3 Series Use>, <4.4 Simultaneous Series& Parallel Use>.

The battery connected to external devices serves as the first battery (Battery1), and we define this battery as the host, while other batteries are the slaves;

The LINK OUT of host battery 1 is connected to the LINK IN of slave battery 2,

Connect the LINK OUT of slave battery 2 to the LINK IN of slave battery 3; and so on.

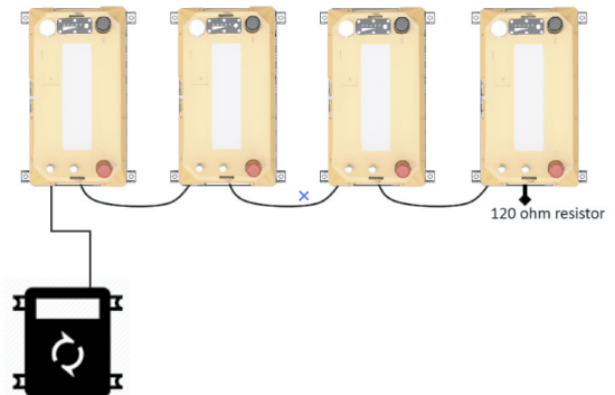

Press the battery switch: switch from OFF to ON

Matching address: After pressing the host battery 1 ON/OFF button for 10 seconds, the indicator light will start running. After all the indicator lights are off, it means that the internal address allocation of the battery is completed;

⚠ ATTENTION

The battery must be connected to the power line in a series first and then in parallel mode; The communication line should first connect the first cluster of series connected batteries, and then connect the second cluster of series connected batteries, without confusion; The matching address must be selected as the host battery 1. Press and hold the ON/OFF button for 10 seconds, and other slave batteries cannot be selected. Press and hold the ON/OFF button. This step is particularly important as improper operation may result in battery networking failure.

2. APP operation (this step needs to match the use of the mobile app and enable the Bluetooth function of the phone):

① Networking: Open the communication networking interface of the APP, click the sign, set the system name, select the voltage platform of the battery, determine the actual number of series and parallel connections, and click next after setting

② Connect to the host: Click on Battery1 to connect to the host battery, select the corresponding host, save, and the network distribution is successful; the device indicator light is constantly on;

③ Maximum allowable series parallel connection for 12V batteries:
 When 1 is connected in series, 16 parallel connections are allowed
 When 2 are connected in series, 4 parallel connections are allowed
 When 3 are connected in series, 4 parallel connections are allowed
 When 4 are connected in series, 4 parallel connections are allowed

APP interface display

1. Support fuzzy search device: search for battery system by name

2. System List:

- ① Display system data: system name, system voltage, system current;
- ② Click "+" to add system configurations, with a maximum of 6 systems saved;
- ③ The switch can connect and disconnect the system;
- ④ Press frequently to delete the system

3. Device List

① Searchable device Bluetooth name, signal strength, device address, and device SOC

Convert M12 communication interface

SKU : ACC-CABLE-PRO_COMM-GX-M12-RJ45F



This cable is used to convert the M12 communication interface on the Volthium PRO series battery to an RJ45 female connection.

To establish communication with the Victron Venus OS environment, please use a Victron VE.CAN cable, and connect it to the Volthium M12-Rj45 adapter.

Please note, the VE.CAN cable must be connected in a particular direction. The M12 side, must be connected to the Link-in port of the battery. Don't forget to press the CAN initialization button for 10 seconds (see page 7)

If you use the VE.CAN cable manufactured by Victron Energy;



Connect the RJ45 tip labeled "Battery BMS Can-type A" into the female Rj45 port of the Volthium adapter.

On the Victron VE.CAN RJ45 cable, the tip labeled "Victron VE.CAN" will connect to the BMS-CAN port of your Venus OS device, such as the Cerbo.

Additional information ; If you do not have a BMS-CAN port in your Venus OS device, but you have a VE.CAN port, you will be able to use it. However, you will need to adjust the parameters of this port in the Venus OS settings.

If you use the VE.CAN cable manufactured by Volthium;

UGS : ACC-CABLE-CANVIC-R-6P

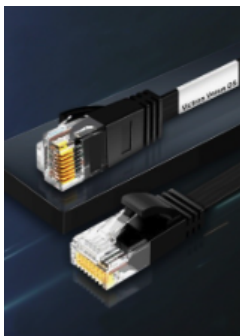

Connect the unidentified RJ45 tip into the female RJ45 port of the Volthium adapter.

On the RJ45 Volthium VE.CAN flat cable, the tip labeled “Victron VenusOS” will connect to the BMS-CAN port of your Venus OS device, such as the Cerbo.

Additional information ; If you do not have a BMS-CAN port in your Venus OS device, but you have a VE.CAN port, you will be able to use it. However, you will need to adjust the parameters of this port in the Venus OS settings.

Snapshot of information on Victron device :

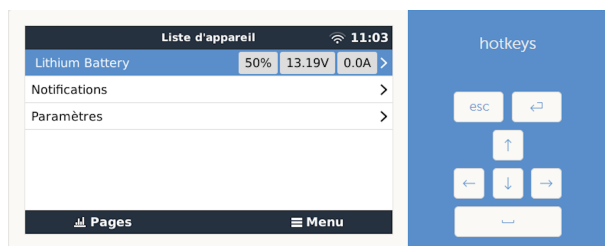

Data collection on windows computer

To collect PRO battery data with a Windows computer, you will need the Volthium USB-RJ45 Cable. ACC-CABUSBR5485-V2



Charging requirements

We recommend using a charging source with specific lithium charging settings to meet the following charging requirements to achieve the optimal performance and lifespan of Volthium Pro series batteries.

Model	Max Charge Voltage	Cut-off Voltage	Maximum Charge Current	Recommended Charge Current	Operation Temperature
48V	57.6V	44.8V	1C	0.3C	Charge: 0-45°C Discharge: -20-65°C
36V	43.2V	33.6V			
24V	28.8V	22.4V			
12V	14.4V	11.2V			

Note : Batteries with heating function need to be heated before switching to charging mode.

AC-DC CHARGER

Check if the AC-DC battery charger you plan to use has a dedicated lithium charging setting that meets the above charging requirements. Many battery chargers are only designed to charge Lead-acid battery and may not have appropriate lithium charging settings.

PHOTOVOLTAIC CHARGING

Check if the solar regulator you plan to use has a dedicated lithium charging setting that meets the above charging requirements. The Volthium Pro series batteries can be charged using a solar regulator without lithium charging settings. However, it must be set to charge no more than 58.4V (4 batteries in series, with a maximum charging voltage of no more than 14.6V for a single battery). After the battery is fully charged, do not open the solar regulator without a suitable lithium charging setting.

CHARGING WITH AN AC GENERATOR THROUGH A DC-DC CHARGER

Check if the DC-DC charger you plan to use has a dedicated lithium charging setting that meets the above charging requirements. You can use a DC-DC charger without lithium charging settings to charge Volthium Pro series batteries. However, it must be set to charge no more than 58.4V (4 batteries in series, with a maximum charging voltage of no more than 14.6V for a single battery), and then it must be turned off after the Volthium Pro series battery is fully charged. After the battery is fully charged, do not turn on the DC-DC charger without a suitable lithium charging setting.

RECOMMENDED CHARGING VOLTAGE

We strongly recommend a dedicated charger for lithium-ion batteries to better fully charge the battery. At the same time, according to the actual situation, AGM chargers can also be used to charge the battery, which can achieve varying degrees of effect.

PASSIVE EQUALIZATION FUNCTION

When the battery is charged close to SOC 100%, due to the chemical characteristics of lithium batteries, the voltage difference between the cells will gradually expand. In order to ensure that each cell has the same capacity, slightly higher capacity cells will choose to "bleed", which can allow the remaining cells to catch up.

Battery recycling

Volthium Pro 12V100Ah batteries are recyclable and should not be treated as household waste or landfill waste. If you need assistance in recycling batteries, please contact your dealer or Volthium's technical support engineer (as mentioned earlier in this manual).

Transportation and Storage



During transportation, there should be no severe vibration, impact, or compression, and it should be protected from sunlight and rain.

Handle with care during loading and unloading, and strictly prevent falling, rolling, and heavy pressure.

The battery should be stored in a dry, clean, dark and well ventilated indoor environment for a long time. The recommended storage temperature range is 15~35°C.

The storage area is free of harmful gases, flammable and explosive materials, and corrosive chemicals.

Batteries should be stored and transported at temperatures close to 50% SOC.

If not used for a long time, the battery needs to be charged every 6 months according to the specifications.

It is strictly prohibited to collapse, and the stacking should not exceed 6 layers, with the surface facing upwards.

Warnings and Attentions

Please carefully read the battery specifications or instructions before use. Improper use may cause the battery to heat up, catch fire, rupture, damage, or decrease capacity. Energie Volthium Inc shall not be responsible for any accidents caused by not following our operating instructions.

WARNING

- The battery must be kept away from heat sources, high voltage, and directly exposed to sunlight.
- Do not throw the battery into water or fire.
- Do not invert the two terminals when using the battery.
- Do not connect the positive and negative poles of the battery to the conductors.
- Do not strike, throw, or step on the battery.
- Do not disassemble the battery without the manufacturer's permission and guidance.
- Do not mix batteries of different capacities and brands.

ATTENTION

- It is recommended to fully charge the battery every month to correct the battery SOC.
- When the battery is discharged, please charge the battery in a timely manner (≤ 2 days).
- Please use a dedicated lithium battery charger to charge the battery.
- Please stop using the battery when it emits odor, heat, deformation, or any abnormalities occur.
- Please place the battery away from children or pets.
- If the battery pack electrolyte leaks, please avoid contact with liquids or leaked gases. If the battery pack electrolyte leaks, please take the following steps immediately.
- Inhalation of gas: Evacuate personnel from the contaminated area and seek medical attention as soon as possible.
- Eye contact: Rinse eyes with water for 15 minutes and seek medical attention as soon as possible.
- Skin contact: Thoroughly rinse the exposed area with soap and water to ensure there are no chemicals or soap residues on it, and seek medical assistance as soon as possible.
- Swallowing: Try to induce vomiting and seek medical attention as soon as possible.
- Fire: Please use carbon dioxide fire extinguishers instead of liquid fire extinguishers to extinguish the fire.

VOLTHIUM LIMITED WARRANTY

10-year limited warranty

Volthium Energy warrants that each Aventura Series LiFePo4 battery sold by Volthium Energy or one of its authorized distributors or dealers is free from defects in performance for a period of 10 years from the date of sale as determined by the customer's sales receipt, shipping invoice and/or battery serial number, with proof of purchase. Subject to the exclusions listed below, the manufacturer will repair if repairable, replace or credit, the product and/or parts of the product, if the components in question are found to be defective.

During the first 4 years of life of your Volthium battery, if applicable under this limited warranty, the amount covered for a new replacement battery will be 100%. Beginning on the first day of the 5th year of life of your Volthium battery, if applicable under this limited warranty, the amount covered for a new replacement battery will be determined according to the table below:

Number of years of defective Volthium battery life under this limited warranty	% of the amount covered for the equivalent Volthium replacement battery included in this limited warranty
5 years	60%
6 years	50%
7 years	40%
8 years	30%
9 years	20%
10 years	15%

The amounts granted above are always conditional on the return of the defective battery to Volthium with proof of purchase.

Warranty statement

This warranty is the only legitimate warranty carried by Volthium Energy. In no event shall the manufacturer be liable for any loss or damage of any other nature, whether direct, indirect or consequential in connection with Volthium brand batteries.

This warranty is understood to be the exclusive agreement between the parties concerning the subject matter hereof. No employee or representative of the manufacturer is authorized to make any warranty in addition to those set forth in this agreement.

Non-transferable warranty

This limited warranty is to the original purchaser of the product and is not transferable to any other person or entity. Please contact the place of purchase for warranty claims.

Warranty exclusions

The manufacturer has no obligation under this limited warranty for products subject to the following conditions (including, but not limited to):

- Damage due to improper installation; loose terminal connections, undersized wiring, incorrect connections (series and parallel) for desired voltage and AH requirements, or reverse polarity connections;
- Environmental damage; inappropriate storage conditions as defined by the manufacturer; exposure to extremely hot or cold temperatures, fire or frost, or water damage;
- Collision damage;
- Damage caused by improper maintenance, under- or overloading of the product, overloading when cold, use of an unsuitable charger;
- Product that has been opened, pierced, modified or tampered with;
- Product used for applications other than those for which it was designed and intended, including repeated engine starting;

Warranty exclusions (CONTINUED)

- Product used on an oversized inverter/charger without the use of a manufacturer-approved surge suppressor;
- Product not stored in accordance with manufacturer's storage guidelines, including storage of product at low state of charge;
- Product that was undersized for use, including an air conditioner or similar appliance with locked rotor starting current that is not used in conjunction with a manufacturer-approved surge-limiting device;
- This limited warranty does not cover a product that has reached the end of its normal life due to excessive use. A battery can only deliver a fixed amount of energy over its lifetime, which will occur over different periods depending on usage. For example, repeated and frequent use of more than one battery cycle per day will result in normal end-of-life before the end of the warranty period. The manufacturer reserves the right to refuse a warranty claim if, upon inspection, it is determined that the product has reached the end of its normal life, even though it remains within its warranty period;
- This limited warranty does not apply to non-essential battery components. These are covered as follows: LCD screen - 1 year; Bluetooth device - 4 years.

Repairs without warranty

For any damage outside the warranty period, or for damage not covered by the warranty, customers can always contact the manufacturer for battery repairs. Costs will be assessed and determined according to current terms and conditions.

Submitting a warranty claim

To submit a warranty claim, please contact Volthium Energy at support@volthium.com or 514 989-9586.

Return and refund policy

If you're not completely satisfied with your purchase, we're here to help.

Return

You have 14 calendar days to return an item from the date of shipment. To be eligible for a return, your item must be brand new (sealed box) and unused. Keep the original packaging for 45 days. Your item must be in its original packaging. Your item must have the receipt or proof of purchase. No returns will be accepted without a secure barcode label number.

Refunds

Once we have received your item, we will inspect it and inform you that we have received your returned item. We will proceed with the refund immediately after inspecting the item and confirming its eligibility.

Delivery

You will be responsible for paying your own shipping costs for the return of your item. Shipping charges are non-refundable. If you receive a refund, the return shipping charges will be deducted from your refund. If you have any questions about how to return your item, please contact us.

Return request

To submit a return request, please contact Volthium Energy at support@volthium.com or 514 989-9586.

ANNEX

TECHNICAL SHEET

ELECTRICAL SPECIFICATIONS

Voltage	12.8 volt
Capacity	100 Ah
Capacity @ 20A	300 min
Energy	1280 Wh
Auto-discharge	<3% per month
Maximum unit in series	4
Maximum unit in parallel	Unlimited

DISCHARGE SPECIFICATIONS

Continuous discharge current	150 A
Peak discharge current	500 A (3s)
Disconnect charge current	300 A (1s)
Low voltage disconnect	11.5 V
Low voltage reconnect	12.8 V
Short circuit protection	Yes

CHARGE SPECIFICATIONS

Recommended charge current	5 A - 60 A
Maximum charge current	100 A
Recommended charge voltage	14.2 V - 14.6 V (Bulk) 13.8 V (Float)
High voltage disconnect	16.7 V
High voltage reconnect	16.4 V

COMMUNICATIONS SPECIFICATIONS

Bluetooth	Embedded
Communication ports	CAN & RS485
LCD screen with battery voltage displayed	Yes
Volthium CAN Hub Communication (VE.CAN)	Compatible

TEMPERATURE SPECIFICATIONS

Discharge temperature	-20 to 60 °C
Charge temperature	0 to 45 °C
High disconnect temperature	60 °C
High reconnect temperature	55 °C
Storage temperature	10 to 45 °C

AUTOHEATING SPECIFICATIONS (OPTIONNAL)

Heating temperature	-45 to 11 °C
Activation current	6 A
Heating current	4 A
Manual activation of heating function possible	Yes

NUMBER OF CYCLES ACCORDING TO THE DISCHARGE %

Discharge 30%	8200 < cycles
Discharge 80%	6000 < cycles
Discharge 100%	3000 < cycles



MECHANICAL SPECIFICATIONS

Dimensions (LxWxH) Group 27	308 X 168 X 211 mm 12.13 X 6.61 X 8.3 po
Weight	27 lbs
Terminal type	M8
Ingress protection marking	IP67
Terminal torque requirement	8~10 nm / 6~8 ft/lb



CERTIFICATIONS & CONCEPTION

Conception	4S1P
Certifications	FULL ETL UL1973 & ABYC E-13
Shipping classification	UN 3480 CLASS 9
Cell type	SquareCell - LiFePO4 - 3.2V - 100A Grade A+



SPECIAL FEATURES RECAP

IP67 | LCD on Top | On/Off Switch |
Cold cranking amps (CCA) 800 | Series+Parallel allowed | Self Heating et Cooling | Victron CAN & NMEA 2000 intégrated | Bluetooth with Daisy-Chain | Over Current limit managa by the mobile APP | Easy Access to BMS | 10 years of Warranty